

AXIAL WAREHOUSE EXHAUST FAN  
 ARRANGEMENT 4, LEVEL 1, ROOF MOUNTED VERTICAL DISCHARGE WITH CURB CAP AND DISCHARGE CAP

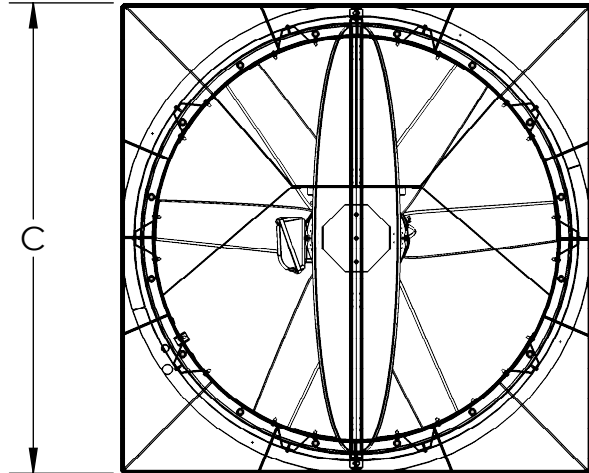

TOP VIEW

**STANDARD CONSTRUCTION:**

1. High efficiency adjustable pitch, cast aluminum airfoil propeller (06 or 09 blades)
2. Bolted access door
3. Bolted switch bracket
4. Welded curb cap
5. Discharge windband
6. Butterfly damper (Galvanized)
7. Air dry enamel coating

**ACCESSORIES:**

1. Butterfly damper (Aluminum)
2. Magnetic latches
3. NEMA 3R service switch
4. Extended lubrication lines (PVC or copper)

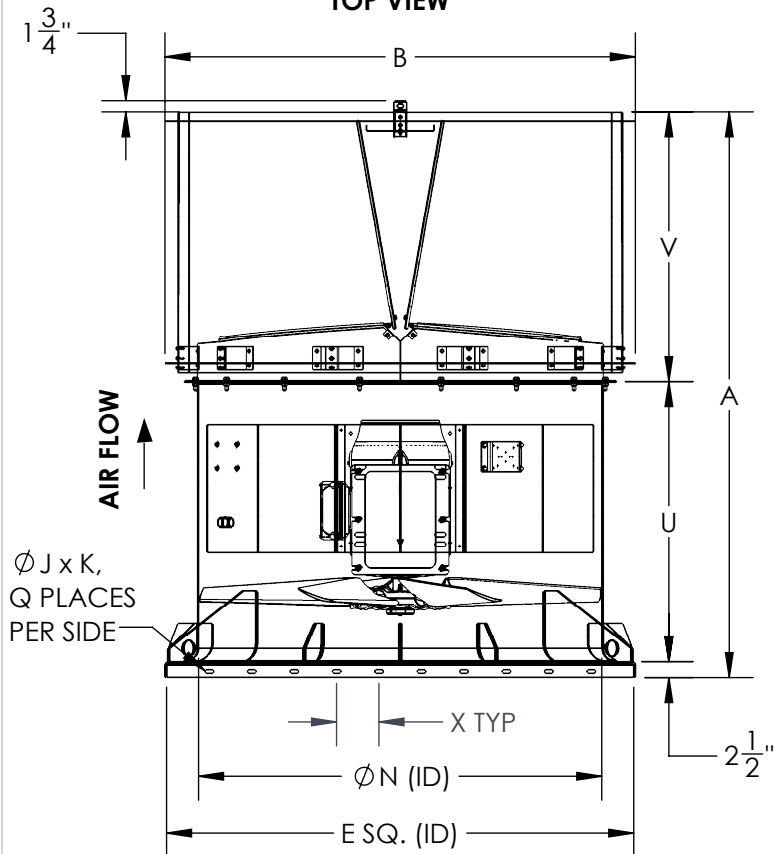

**DIMENSIONAL DATA:**

SIZE	A	B	C	ESQ.	J	K	N	Q	U	V	X	MIN. MTR FRAME	MAX. MTR FRAME	UNIT WEIGHT (LESS MOTOR)
AWX-1600	90 1/4	73 1/2	73 1/2	73	9/16	1 1/8	63	8	46 1/4	42 1/4	6 5/8	213T	286T	1180

ALL DIMENSIONS ARE INCHES AND WEIGHTS IN LBS.

REVISION:

FORM:

REPLACES: